

* = Masse durch Formkonisität nach unten verringert.
Frei-mess - Toleranz nach GTA 13/6 DIN 1698

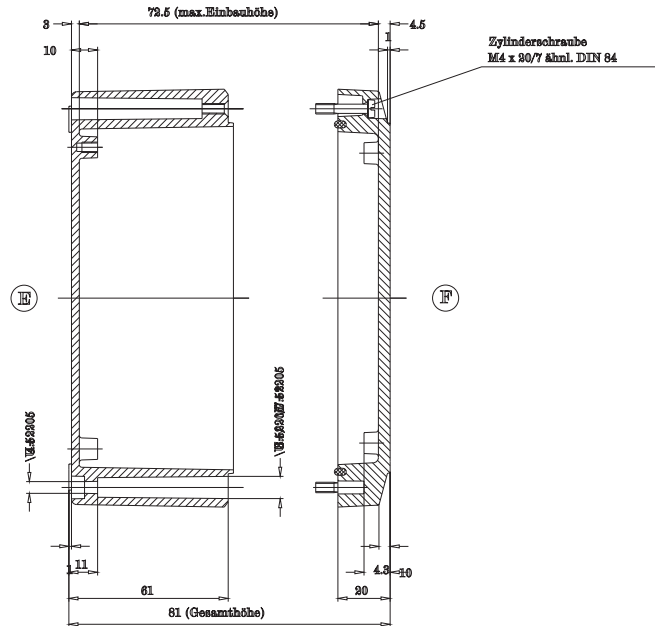
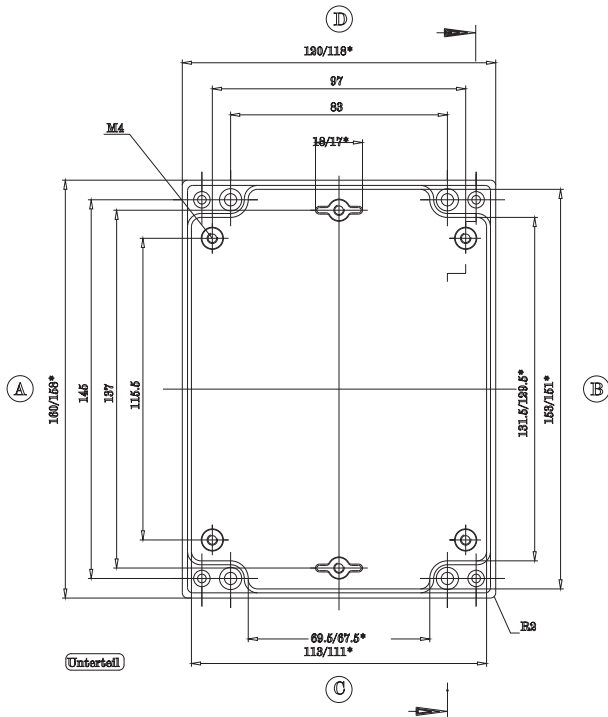
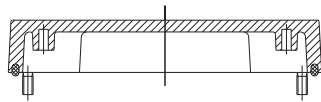

GH02AL005/070

Maße in mm